

STANDARD EQUIPMENT FOR FIELD INSTALLATION

KEY NO.	QTY.	DESCRIPTION
1	1	36 x 36" BASE
2	2	3-5/16" x 77-3/16" FRONT PANEL
3	2	31-5/8 x 77-3/16" SIDE PANEL
4	1	31-5/8 x 77-3/16" BACK PANEL
5	4	CORNER JOINT
6	1	TOP FRAME
-	1	ROD AND CURTAIN
-	1	PRESSURE BALANCED VALVE AND HEAD
-	1	SOAP DISH

FOR CORRECT INSTALLATION:

1. ESTABLISH PROPER CLEARANCE BETWEEN SHOWER BASE AND WALLS.
2. SET SHOWER BASE ON MORTAR BED AND CAREFULLY LEVEL TO AVOID PROBLEMS OF UNEVEN SUB FLOOR.

OPTIONS

- FILLER STRIP (KEY NO. 7)
- FINISH:
 - POWDER COAT ON GALVANIZED STEEL
 - HIGH DENSITY POLYMER (H.D.P.)
 - STAINLESS STEEL
 - SOLID PHENOLIC CORE (S.P.C.)
- THERMOSTATIC VALVE
- TOP COVER
- TOP COVER WITH LIGHT
- VALVE BY OTHERS
- COLOR:
 - WHITE
 - OPTIONAL

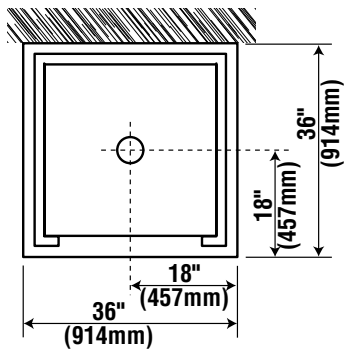
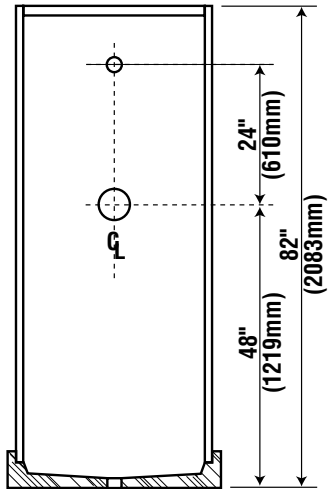

Note: All dimensions subject to manufacturing variance of plus or minus 1/4" (6 MM).