

ROUGHING-IN MEASUREMENTS

Service Sink Fitting with adjustable wall brace, spring checks, integral stops, vacuum breaker, and bucket hook.

Polished chrome finish T-15-VB

Rough chrome finish T-10-VB

1. Measurements shown are subject to revision or cancellation. Do not use superseded or obsolete leaflets.
2. These measurements may vary $\pm 1/4"$ (6 mm) and are for this installation only.
- 3) Flow rate is 2.5 gpm at 60 psi.

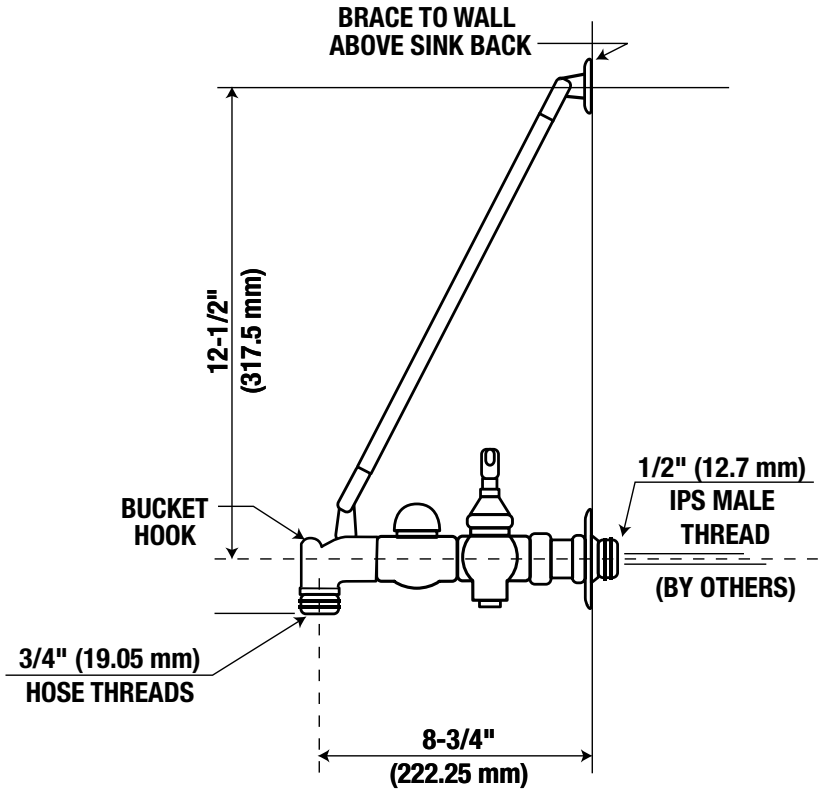
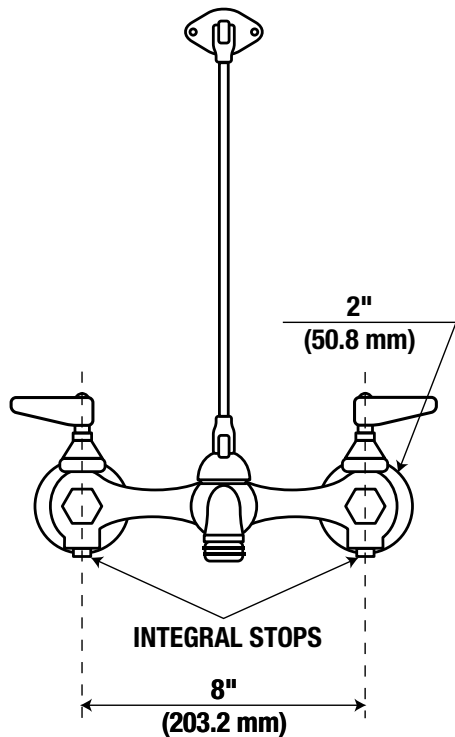
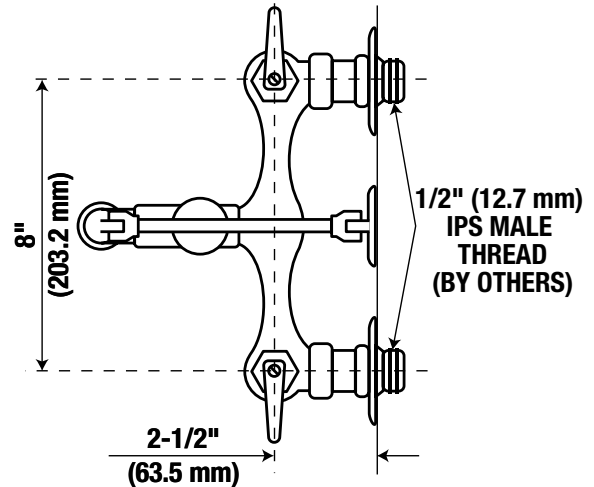

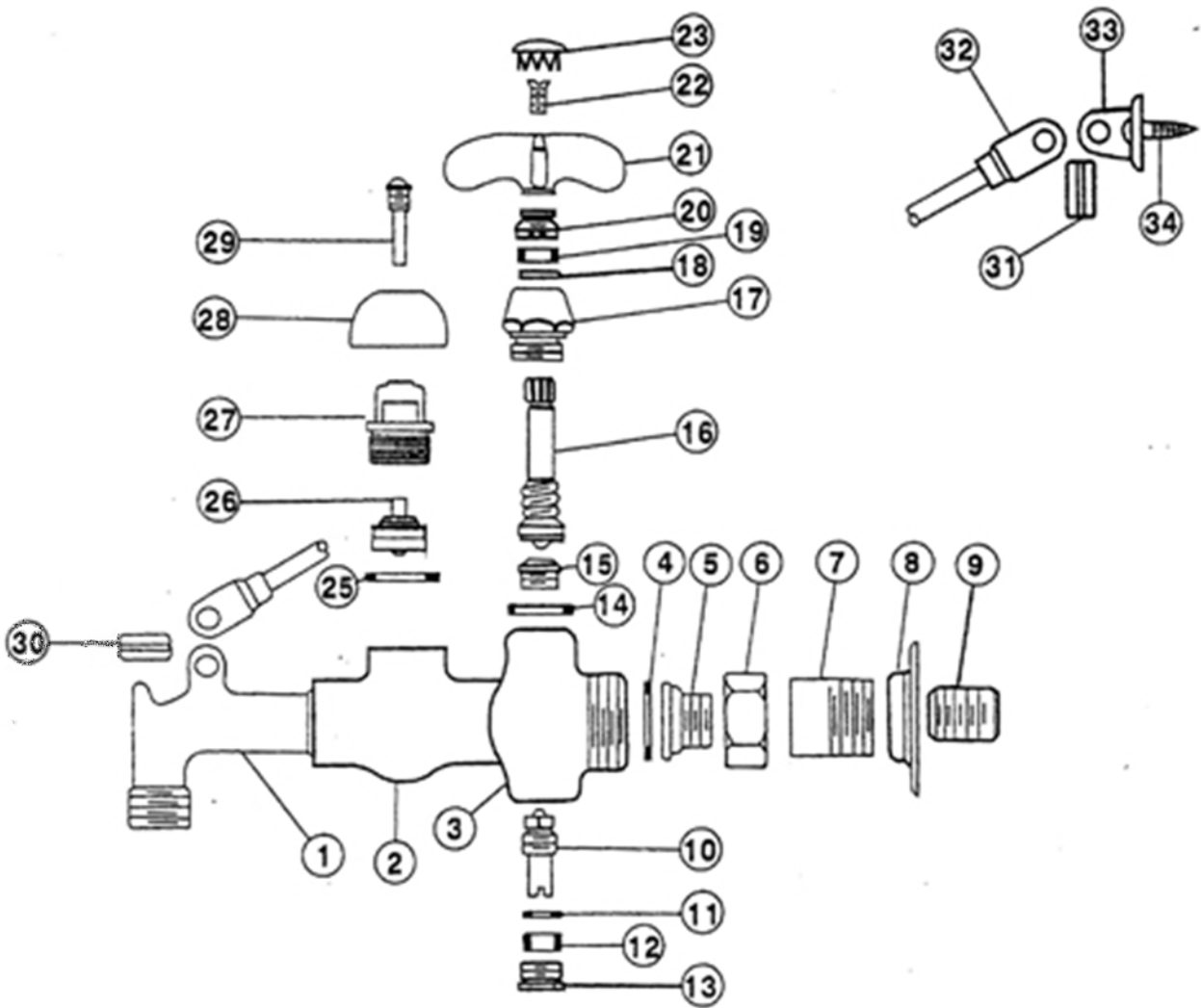

Manufactured 9/99 – 3/07

T-10-VB AND T-15-VB SERVICE SINK FITTING

NO.	QTY. PER	DESCRIPTION	NO.	QTY. PER	DESCRIPTION
1	1	Service Sink Nozzle	19	2	Neoprene Packing
2	1	Vacuum Breaker Body	20	2	Packing Nut
3	1	Valve Body	21	2	Zinc Handle
4	2	Fibre Washer	22	2	Handle Screw
5	2	Swivel	23	2	Index
6	2	Coupling Nut	24		
7	2	Bushing	25-N	1	O-Ring
8	2	Flange	26-N	1	Vacuum Breaker Washer Assembly (Plastic)
9	2	Nipple	27-N	1	Vacuum Breaker Hub
10	2	I.S. Spindles	28	1	Vacuum Breaker Cap
11	2	Brass Washer	29-N	1	Vacuum Breaker Screw (Cap)
12	2	Neoprene Packing	30	1	Brace Pin (SS)
13	2	Packing Nut	31	1	Brace Pin (SS)
14	2	P.E. Washer	32	1	Brace Assembly
15	2	Brass Seat	33	1	Brace Flange
16	2	Valve Spindle	34	2	Wood Screw
17	2	Hub			
18	2	Brass Washer			

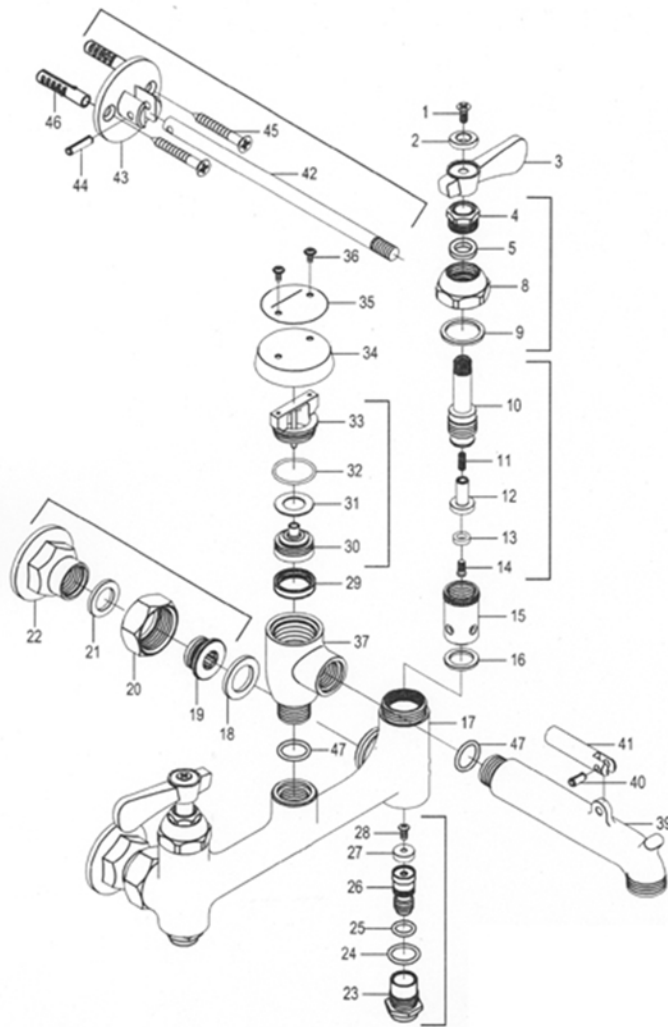

**DISTRIBUTED AFTER NOVEMBER 1, 2012
T-10-VB and T-15-VB SERVICE SINK FITTING**

NO.	Q'TY PER	DESCRIPTION	NO.	Q'TY PER	DESCRIPTION
12-1	2	BRASS HANDLE SCREW	12-26	2	BRASS STEM
12-2	2	POM BUTTON (COLD-BLUE I HOT-RED)	12-27	2	RUBBER WASHER
12-3	2	ZINC LEVER HANDLE	12-28	2	BRASS SCREW
12-4	2	BRASS PACKING NUT (Part 4 includes 5,6,7,8 & 9)	12-29	1	SILICON RING (Part 29 includes 30,31,32 & 33)
12-5	2	NSF RUBBER WASHER	12-30	1	P.P PISTON (FLOAT)
12-8	2	BRASS BONNET NUT	12-31	1	SILICON DISK SEAL
12-9	2	NSF RUBBER WASHER	12-32	1	RUBBER O-RING
12-10	2	BRASS STEM (COLD-LH/HOT-RH) (Part 10 includes 11,12,13 & 14)	12-33	1	PLASTIC INSERT
12-11	2	STAINLESS STEEL SPRING	12-34	1	BRASS COVER PLATE
12-12	2	BRASS SEAT	12-35	1	ALUMINUM NAME PLATE
12-13	2	NSF RUBBER WASHER	12-36	2	STAINLESS STEEL SCREW
12-14	2	BRASS SCREW	12-37	1	BRASS VACUUM BREAKER BODY (* Not available as replacement part.)
12-15	2	BRASS BLOCK (COLD-LH/HOT-RH)	12-39	1	BRASS SPOUT (* Not available as replacement part.)
12-16	2	NSF RUBBER WASHER	12-40	1	STEEL SPRING PIN (* Not available as replacement part.)
12-17	1	BRASS FAUCET BODY (* Not available as replacement part.)	12-41	1	STAINLESS BRASS CONNECTOR (* Not available as replacement part.)
12-18	2	RUBBER WASHER	12-42	1	BRASS WALL BRACE (Part 42 includes 43 & 44)
12-19	2	BRASS INSERT (Part 19 includes 20, 21 & 22)	12-43	1	ZINC WALL FLANGE
12-20	2	BRASS HEX. NUT	12-44	1	STAINLESS STEEL SPRING PIN
12-21	2	NYLON RING	12-45	2	STAINLESS STEEL WALL SCREW
12-22	2	BRASS OFFSET FLANGE	12-46	2	PLASTIC ANCHOR
12-23	2	BRASS STOP BLOCK (Part 23 includes 24,25,26,27 & 28)	12-47	2	RUBBER O-RING
12-24	2	RUBBER O-RING			
12-25	2	RUBBER O-RING			

