

MODEL 5320-RV
 Barrier free, dual level drinking fountain
 Mounting: Wall Mount
 Higher unit on left

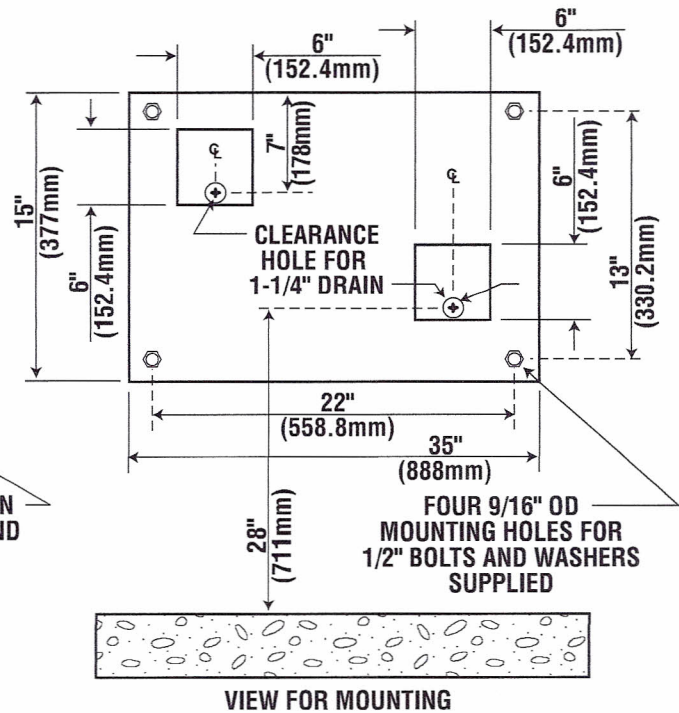
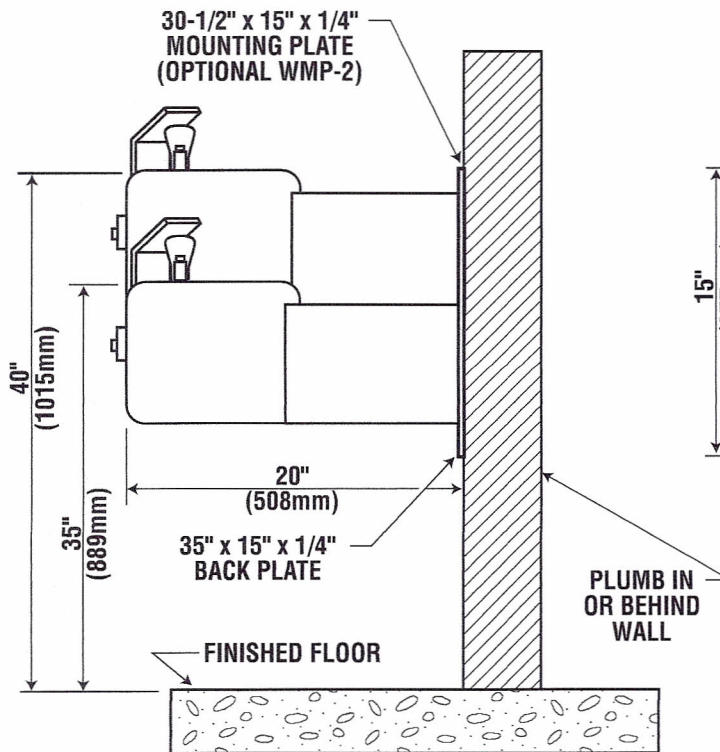
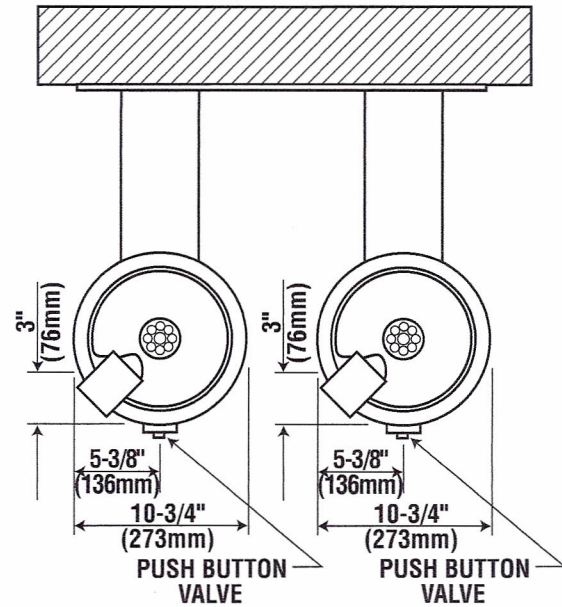
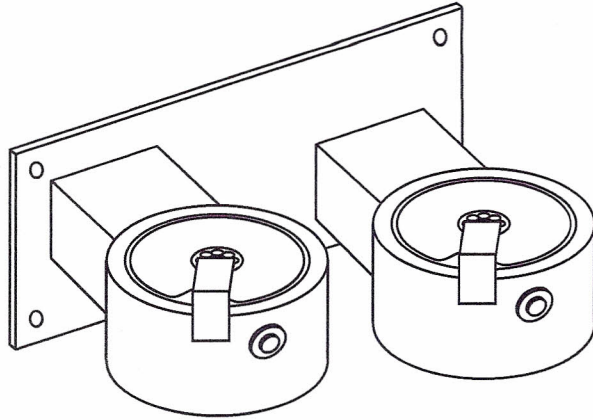

NOTE: OPTIONAL FLOOR SUPPORT CARRIER
 FLWMP-2-RV-FM IS AVAILABLE AND ADVISABLE
 FOR IN WALL INSTALLATION.

NOTE: THESE ROUGH-IN DIMENSIONS
 MAY VARY 1/2: (13 mm) PLUS OR MINUS

Note: All dimensions subject to manufacturing variance of plus or minus 1/4" (6 MM).