

MODEL 5320
Barrier free, dual level drinking fountain
Mounting: Wall Mount

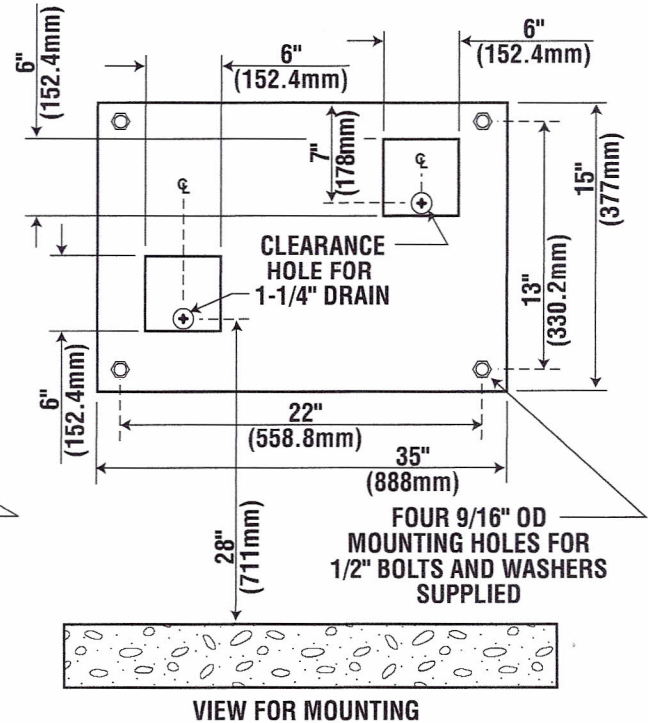
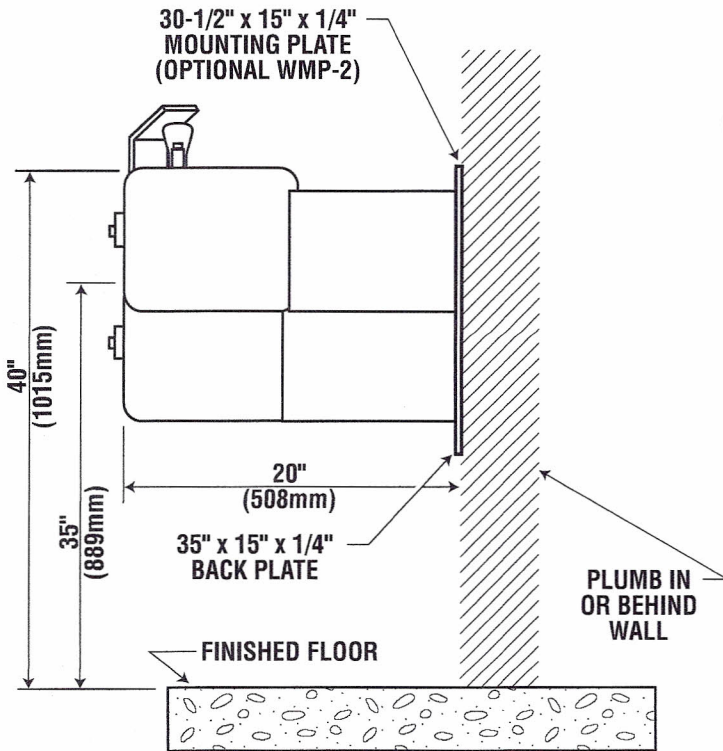
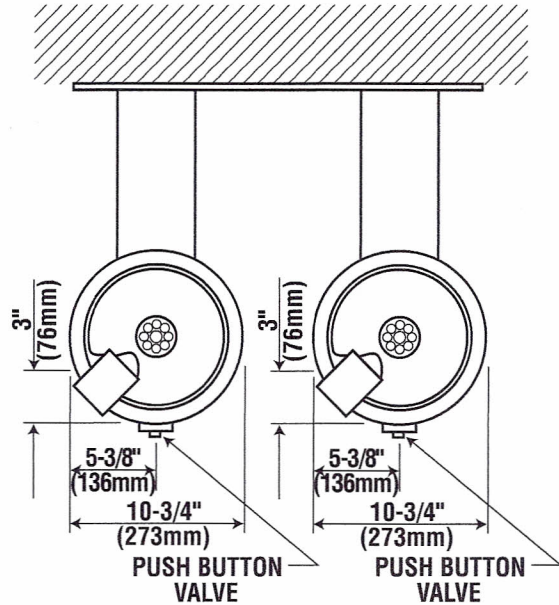
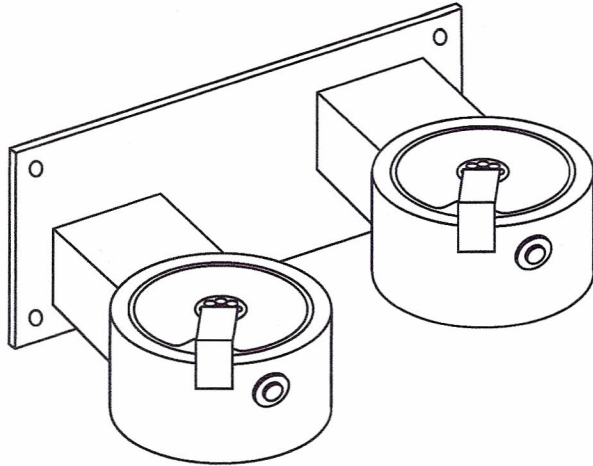

**NOTE: OPTIONAL FLOOR SUPPORT CARRIER
FLWMP-2-FM IS AVAILABLE AND ADVISABLE
FOR IN WALL INSTALLATION.**

NOTE: THESE ROUGH-IN DIMENSIONS
MAY VARY 1/2" (13 mm) PLUS OR MINUS

Note: All dimensions subject to manufacturing variance of plus or minus 1/4" (6 MM).