

## MODEL 5315 & 5320 DUAL WALL MOUNTED DRINKING FOUNTAINS

Striking design with clean, sleek lines. Designed to defy the elements, resist vandals and stand up to hard use. The chrome-plated brass bubbler is locked to the stainless steel receptor. Push button valve is vandal resistant and recessed in steel plate.

ADA Compliant

Model 5315 is dual concealed wall mount with backplate  
 Model 5320 has four bolts with a dual front wall mount with backplate



(Shown above) Model 5315

### FEATURES

- All steel heavy-duty construction with welded and ground joints for a clean and tidy appearance
- Stainless Steel (-SS) bodies available for harsh coastal environments
- Vandal resistant access plates for security and simple future maintenance
- Vandal resistant Fabricated bubbler guard unique to Stern Williams Fountains assures years of service
- Water pressure range of 30-80 PSI
- Optional WMP-2 (5315) or WMP-2-FM (5320) mounting plates for installation assistance
- Optional FLWMP-2 (5315) or FLWMP-2-FM (5320) floor support carried is available and advisable for in wall installation
- Recessed push button requires less than 5 lbs of force and is manufactured from chrome plated brass for reliability and long wear life with a water flow of 0.5 GPM
- Simple flow adjustment without requiring the dismantling of the fountain
- Fountain Bowl is heavy duty 18 gauge stainless steel with brushed finish and vandal-resistant chrome plated brass strainer. A drain tool is included with each fountain
- All flow paths are lead-free with reinforced stainless-steel tubing that complies with NSF/ANSI/CAN 61: Q≤1 (AB100) standards
- Stainless steel supply fittings connected to reinforced tubing
- Inline mesh screen Y strainer
- ½” Inlet stop valve for simple future maintenance
- 1-1/4” IPS waste pipes included with every fountain
- Standard Woodland Green Finish with Optional colors



## ORDERING OPTIONS

Part Number

**5315-**



**Optional**

- 40:** Commemorative Plaque
- 84:** Water Filter
- BFCA-15:** Cane Touch Apron
- FLWMP-2:** Support carrier with mounting plate
- RV:** Reverse Heights
- SS:** Stainless Steel Body Upgrade
- WMP-2:** Mounting Plate

**5320-**



**Optional**

- 40:** Commemorative Plaque
- 84:** Water Filter
- BFCA-15:** Cane Touch Apron
- FLWMP-2-FM:** Support Carrier with Mounting Plate
- RV:** Reverse Heights
- SS:** Stainless Steel Body Upgrade
- WMP-2-FM:** Mounting Plate

**5315-FP-**

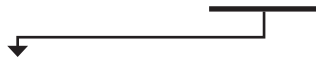

**Optional**

- 40:** Commemorative Plaque
- FLWMP-2:** Support Carrier with Mounting Plate
- RV:** Reverse Heights
- SS:** Stainless Steel Body Upgrade
- WMP-2:** Mounting plate

**5320-FP-**

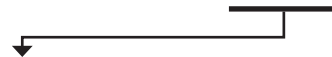

**Optional**

- 40:** Commemorative Plaque
- 84:** Water Filter
- FLWMP-2-FM:** Support Carrier with Mounting Plate
- RV:** Reverse Heights
- SS:** Stainless Steel Body Upgrade
- WMP-2-FM:** Mounting Plate

\*A maximum of 3 options may be added to a fountain.

-FP are frost proof models

## SPEC

Furnish and install Stern-Williams Dual Wall Mounted Drinking Fountain (specify model # and options). Drinking fountain shall be carbon steel or 304 stainless steel and a powder coated finish. Fountain shall have chrome plated brass bubblers with vandal resistant bubbler guard. Water pressure range shall be 30-80 PSI. Fountains shall provide for simple flow adjustment without requiring dismantling of fountain with a water flow of 0.5 GPM. Joints must be welded and ground smooth. Push buttons shall require less than 5 lbs of force in compliance with ADA code. Fountains shall be installed per manufacturers recommendations and instructions. Drinking fountain flow paths are lead-free with reinforced stainless-steel tubing that complies with NSF/ANSI/CAN 61: Q≤1 (AB100) standards. Made in the USA.

## DIMENSIONS

All dimensions subject to manufacturing variance of plus or minus 1/4" (6 mm)

- 5315** 13"H x 20" L / Dual concealed wall mounted with back plate
- 5315-FP** 13"H x 20" L / Dual concealed wall mounted with back plate & freeze-proof valve system
- 5320** 13"H x 20" L / Dual front wall mounted with four bolts & back plate
- 5320-FP** 13"H x 20" L / Dual front wall mounted with four bolts, back plate & freeze-proof valve system

### 5315

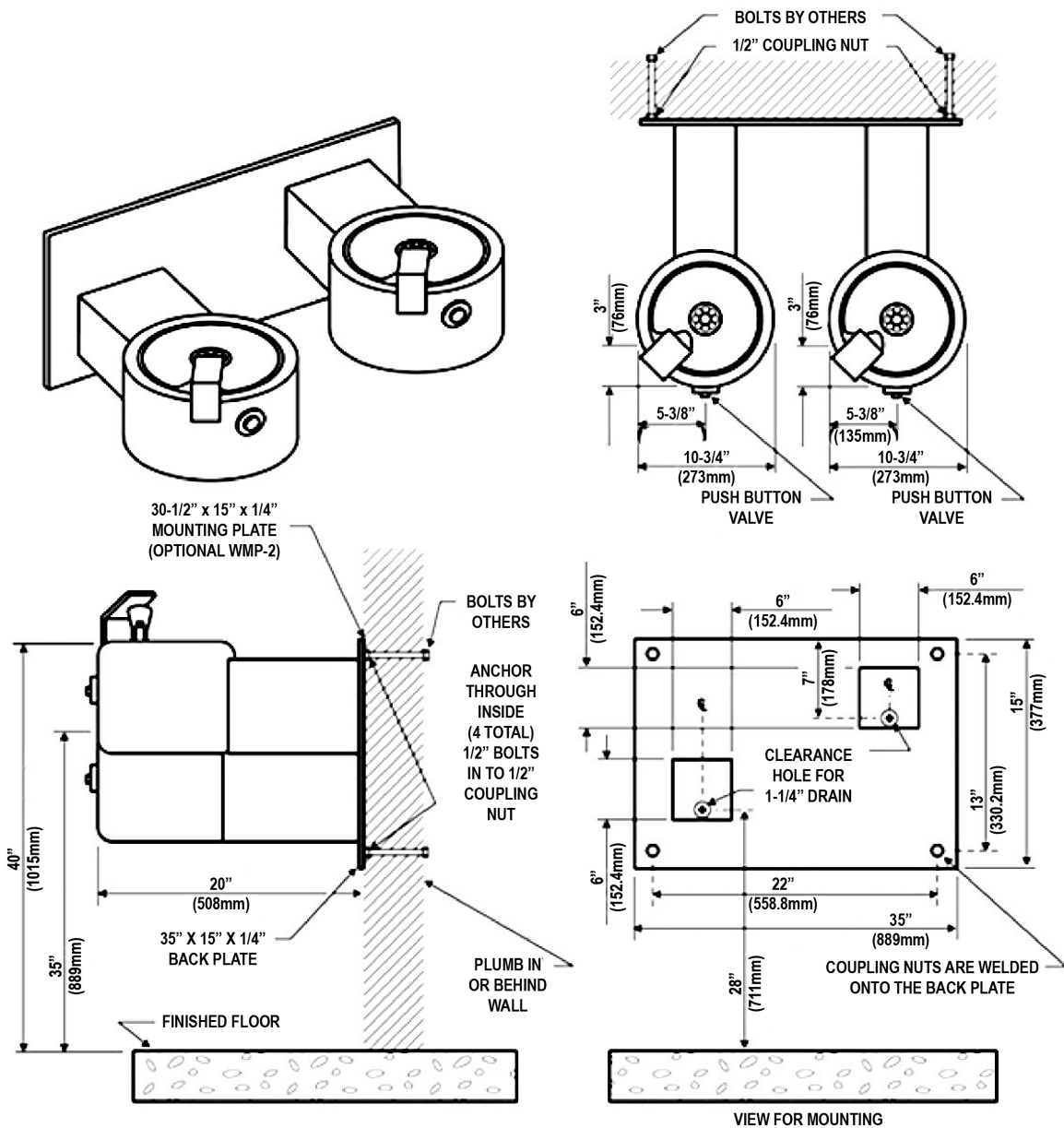

NOTE: OPTIONAL FLOOR SUPPORT CARRIER  
FLWMP-2 IS AVAILABLE AND ADVISABLE  
FOR IN WALL INSTALLATION

**5315-RV**

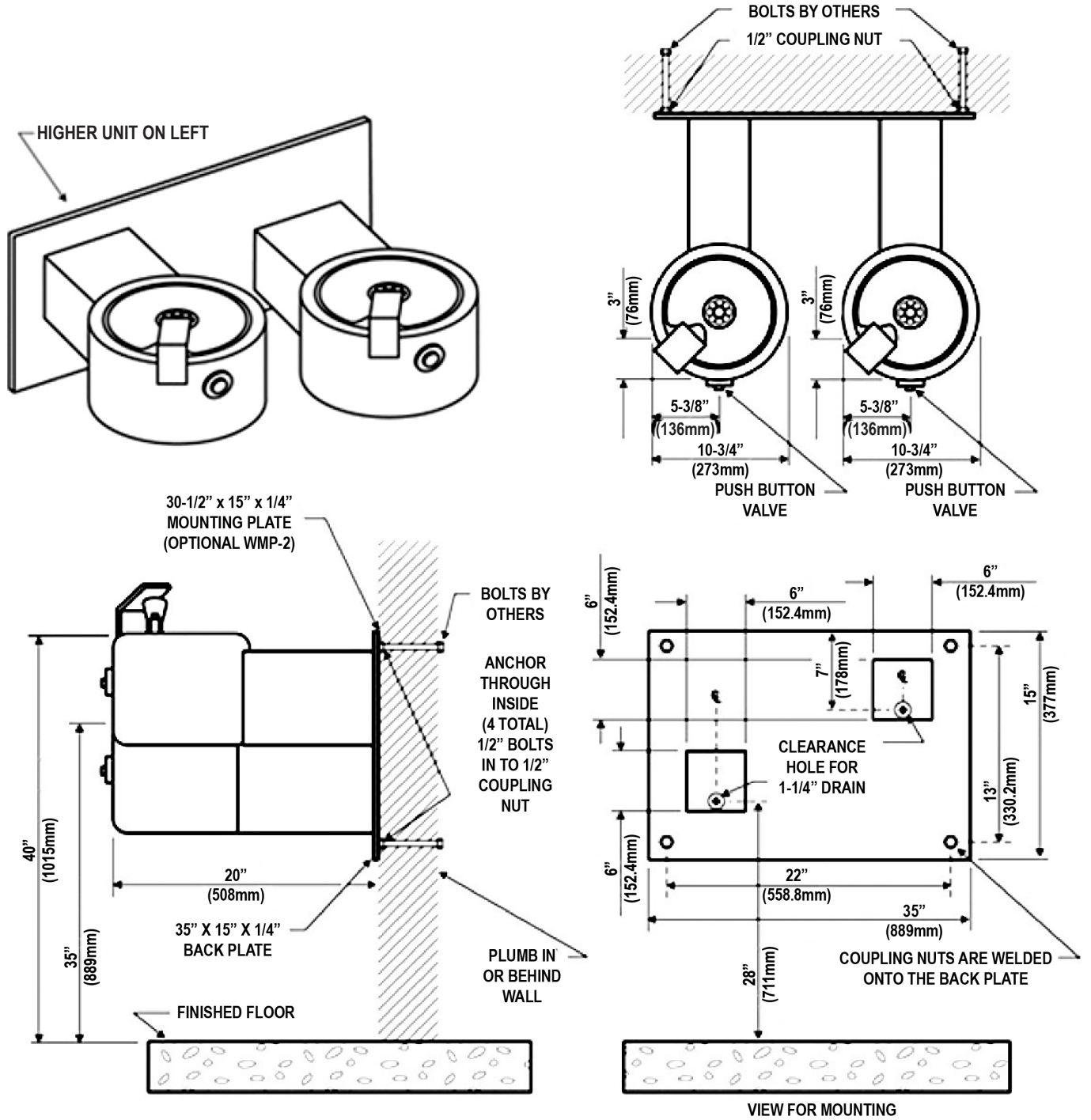

NOTE: OPTIONAL FLOOR SUPPORT CARRIER FLWMP-2-RV IS AVAILABLE AND ADVISABLE FOR IN WALL INSTALLATION

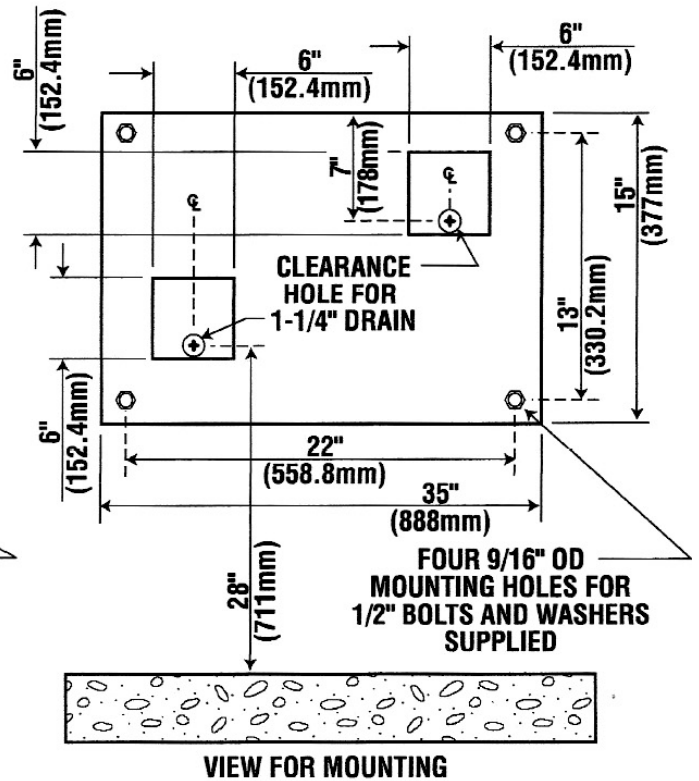
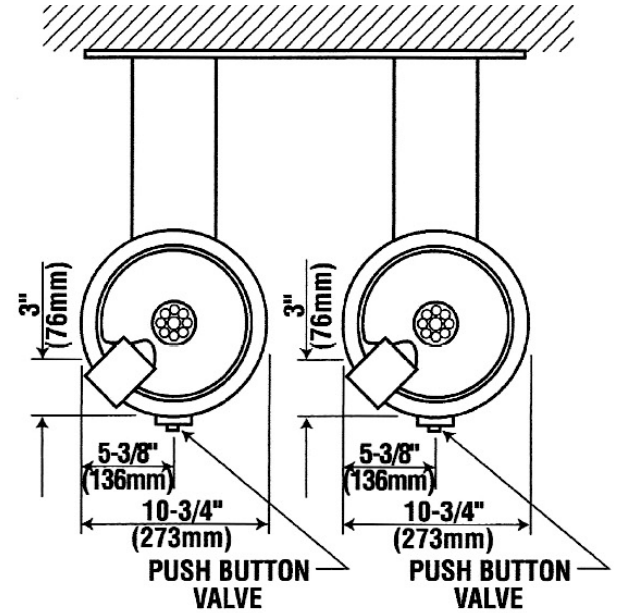
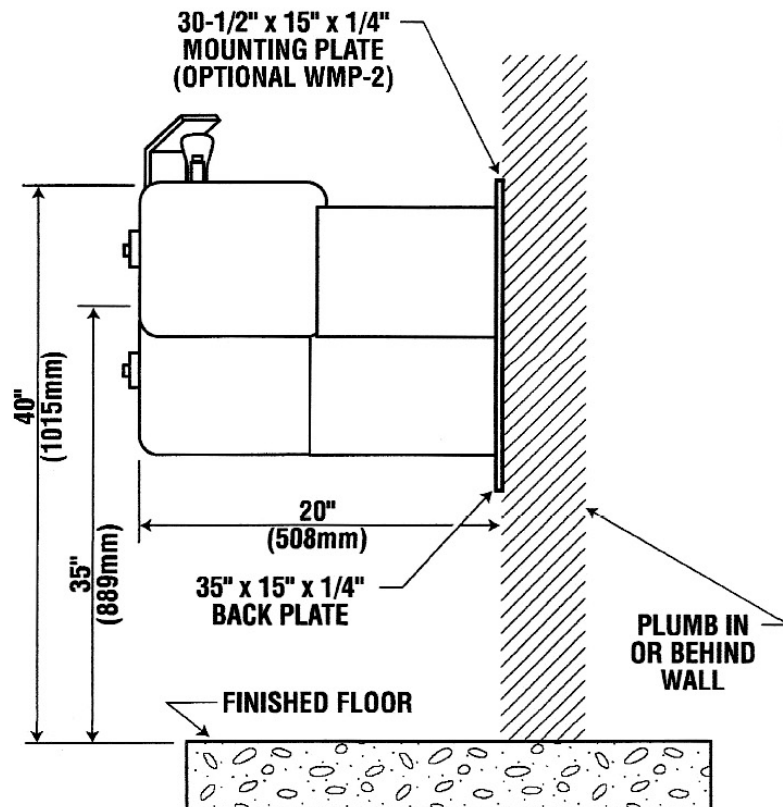
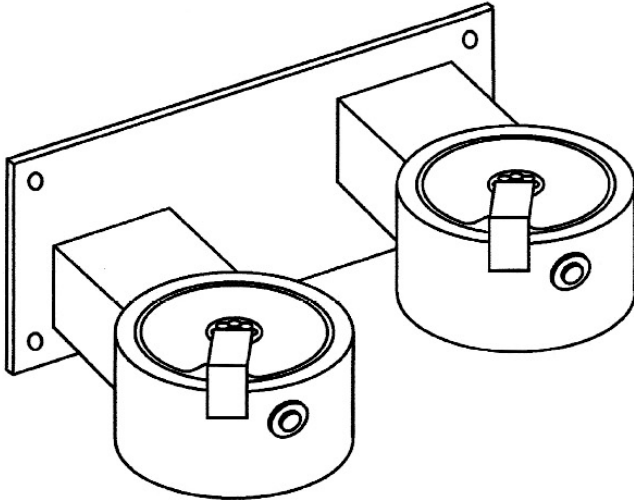

**NOTE: OPTIONAL FLOOR SUPPORT CARRIER  
FLWMP-2-FM IS AVAILABLE AND ADVISABLE  
FOR IN WALL INSTALLATION.**



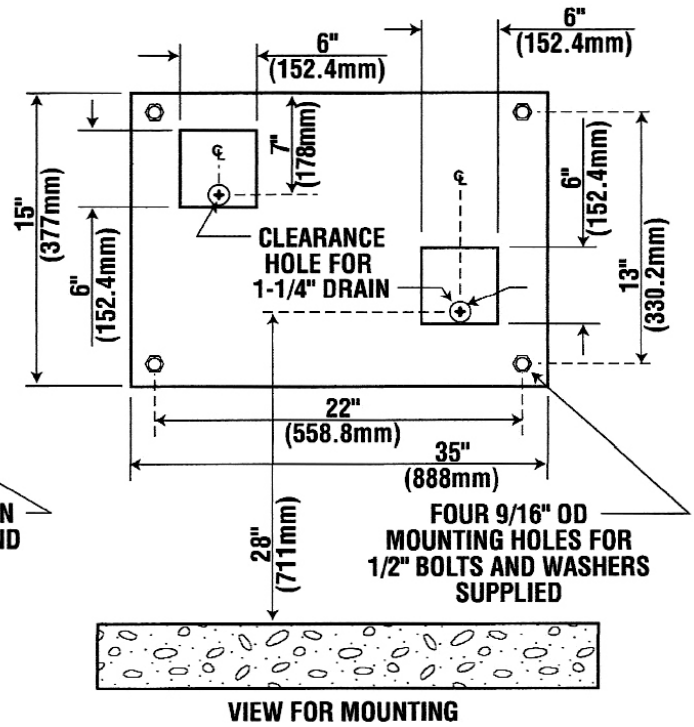
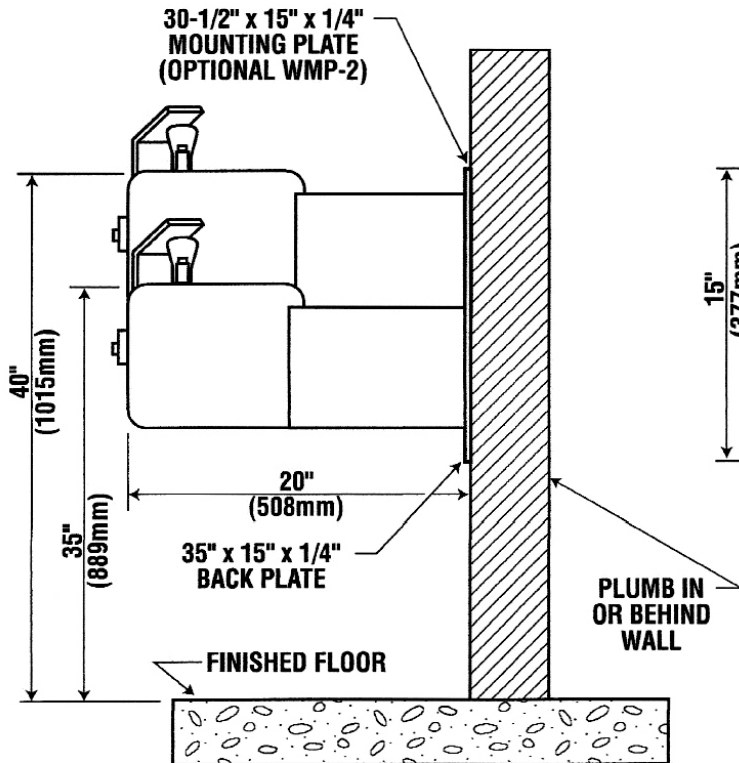
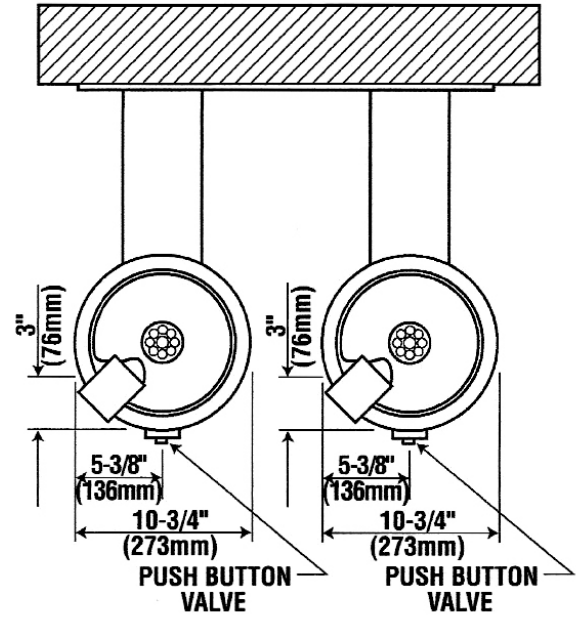
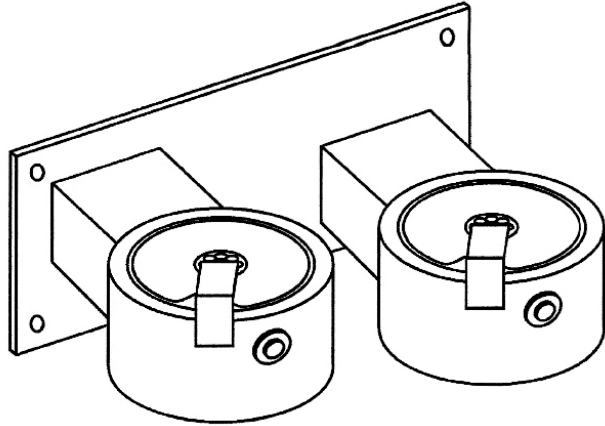

**NOTE: OPTIONAL FLOOR SUPPORT CARRIER  
FLWMP-2-RV-FM IS AVAILABLE AND ADVISABLE  
FOR IN WALL INSTALLATION.**