

## MODEL BF-5000, BF-5020 & BF-5040

### BARRIER-FREE STAINLESS STEEL WALL MOUNTED FOUNTAIN

Lustrous satin-finish stainless steel satisfies the criteria for cleanliness and easy care in medical centers and office buildings. Push button control located on front panel. Vandal resistant bottom plate and mounting plate are standard. Beveled front with or without back plate.

-FP are frost proof models. It is recommended that a dual check valve backflow prevention be installed in the waterline going to any FP fountain.

Model BF-5000 and BF-5000-FP are two levels with back plate  
 Model BF-5020 and BF-5020-FP are single with back plate  
 Model BF-5040 and BF-5040-FP are single with front push button



Model BF-5040



Model BF-5020



Model BF-5000

## FEATURES

- 18 gauge brush finished 304 stainless steel receptor with a vandal resistant chrome plated brass drain plug
- Mounting plate comes standard
- Attractive, protective stainless steel back plate
- Vandal resistant access plates for security and simple future maintenance.
- Push button requires less than 5 lbs of force and is manufactured from chrome plated brass for reliability and long wear life with a water flow of 0.5 GPM.
- Simple flow adjustment without requiring the dismantling of the fountain.
- Fountain Bowl is heavy duty 18 gauge stainless steel with brushed finish and vandal-resistant chrome plated brass strainer. A drain tool is included with each fountain.
- All flow paths are lead-free with reinforced stainless-steel tubing that complies with NSF/ANSI/CAN 61: Q≤1 (AB100) standards.
- Stainless steel supply fittings connected to reinforced tubing
- In-line mesh screen Y strainer.
- ½" Inlet stop valve for simple future maintenance.
- 1 ¼" IPS waste pipes included on each fountain.

## ORDERING OPTIONS

Part Number

### BF-5000-



**Optional**

- BFCA-1:** Cane Touch Apron
- RV:** Reverse heights

### BF-5000-FP-



**Optional**

- BFCA-1:** Cane Touch Apron
- RV:** Reverse heights

### BF-5020-



**Optional**

- BFCA-1:** Cane Touch Apron

### BF-5020-FP-



**Optional**

- BFCA-1:** Cane Touch Apron

### BF-5040-



**Optional**

- BFCA-1:** Cane Touch Apron

### BF-5040-FP-



**Optional**

- BFCA-1:** Cane Touch Apron

## DIMENSIONS

All dimensions subject to manufacturing variance of plus or minus 1/4" (6 mm)

**BF-5000** 14-7/8"H x 35"W with 18-1/2" extension

**BF-5020** 9-5/8"H x 19"W with 18-1/2" extension

**BF-5040** 7"H x 12"W with 18" extension

## SPEC

Furnish and install Stern-Williams Barrier-Free Stainless Steel Wall Mounted Drinking Fountain (specify model # and options). Drinking fountain shall 304 stainless steel with 18 gauge brush finish. Fountain shall have chrome plated brass bubblers with vandal resistant bubbler guard. Water pressure range shall be 30-80 PSI. Fountains shall provide for simple flow adjustment without requiring dismantling of fountain with a water flow of 0.5 GPM. Push buttons shall require less than 5 lbs of force in compliance with ADA code. Fountains shall be installed per manufacturers recommendations and instructions. Drinking fountain flow paths are lead-free with reinforced stainless-steel tubing that complies with NSF/ANSI/CAN 61: Q≤1 (AB100) standards. Made in the USA.

**BF-5000**

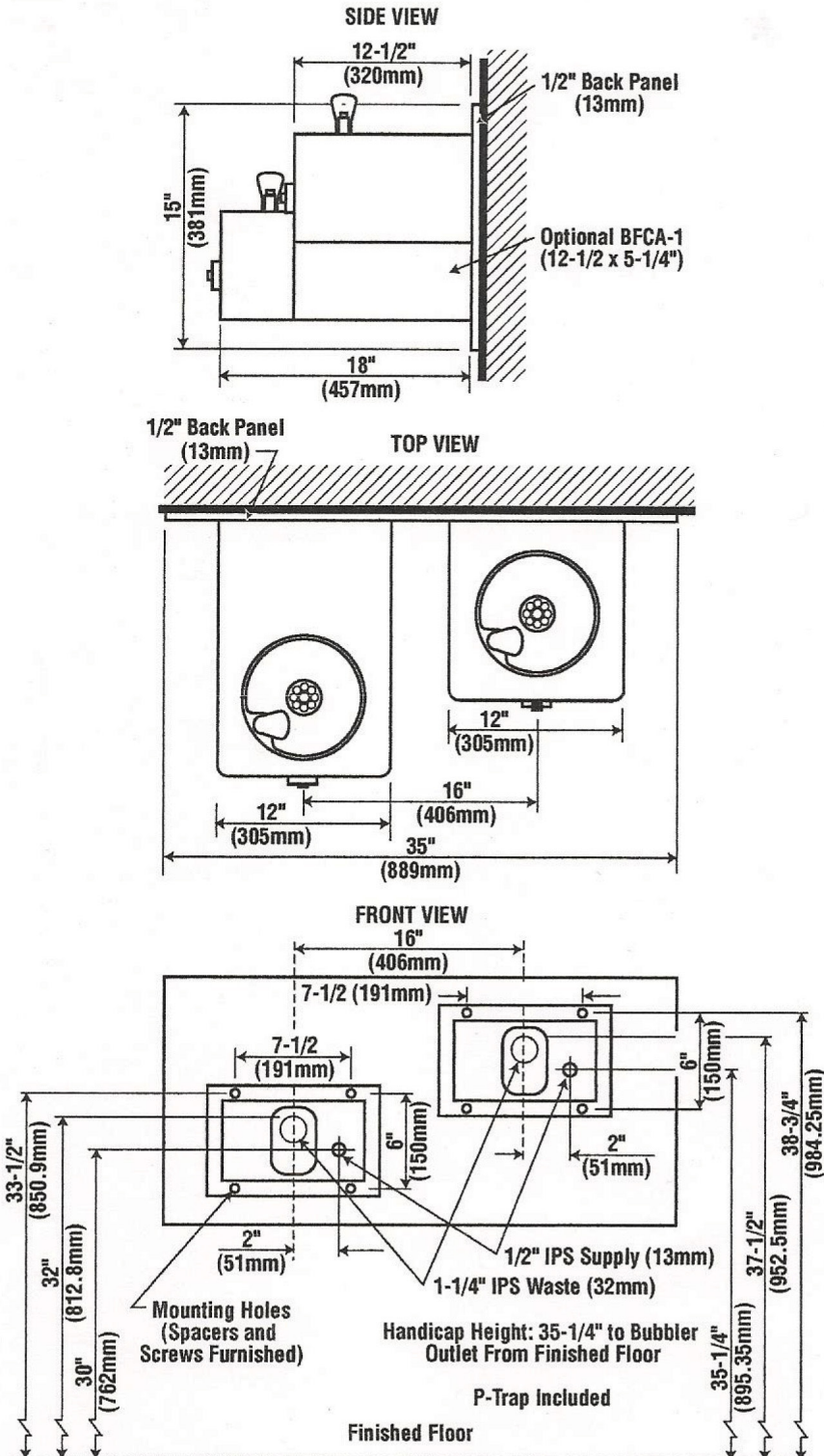

**BF-5020**

**BF-5020 Top View**

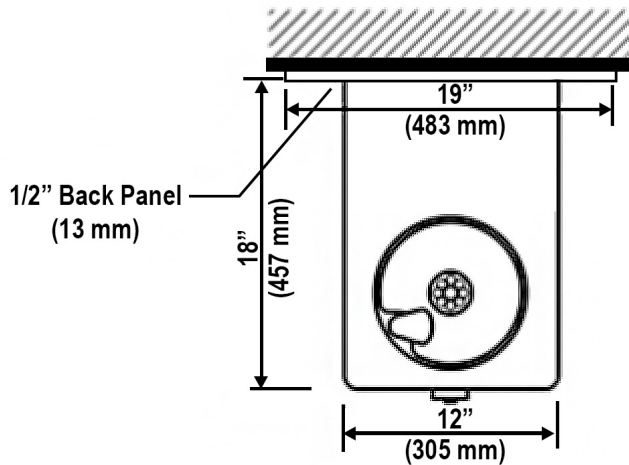

**BF-5020 - WITH BACK PLATE**

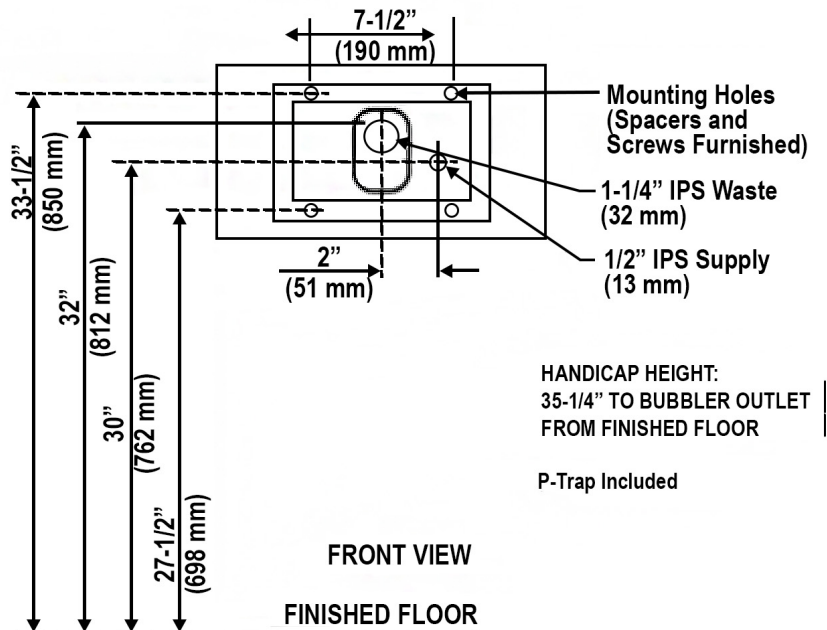
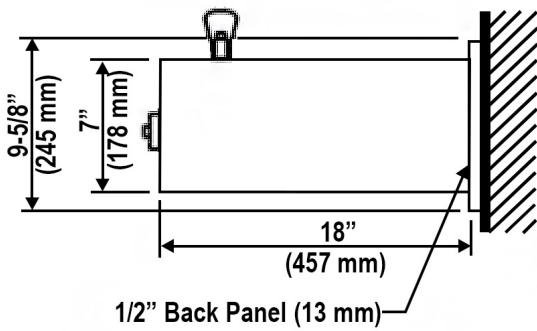

HANDICAP HEIGHT:  
35-1/4" TO BUBBLER OUTLET  
FROM FINISHED FLOOR

P-Trap Included

**BF-5040**

**BF-5040 Top View**

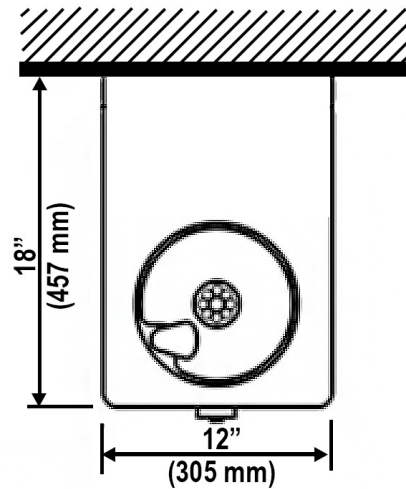

**BF-5040 - WITHOUT BACK PLATE**

