

MODEL SPFR-3100 REFRIGERATED AGGREGATE FOUNTAIN

Electric water chiller aggregate drinking fountain delivers 8.0 gallons per hour of chilled drinking water, making it an ideal hydration solution for parks, campuses, athletic facilities, recreation areas, and other high-traffic outdoor environments in warm climates.

FEATURES

- 8.0 GPH hermetically sealed removable refrigeration system with reciprocating compressor (remote chiller)
- Vandal resistant access plates for security and simple future maintenance
- 18 gauge stainless steel with chrome plated brass drain plug
- Two non cartridge type recesses chrome plated brass push button assembly with adjustable flow regulation
- Chrome plated brass bubbler, locked to receptor with optional stainless steel bubbler guards (-42)
- Fountain bowl is heavy duty 18 gauge stainless steel with brushed finish and vandal-resistant chrome plated brass strainer. A drain tool is included with each fountain.
- All flow paths are lead-free with reinforced stainless-steel tubing that complies with NSF/ANSI/CAN 61: Q≤1 (AB100) standards
- ½" reinforced vinyl tubing with ½" IPS hook-up and stainless steel fittings
- 1 ¼" IPS schedule 40 PVC waste pipes and flexible hose included on each fountain
- 20" x 20" pedestal precast aggregate stone
- Surface mount, 24" x 24" stainless steel mounting plate with four bolt holes, ground installed mounting plate available as an option for installation assistance (SMP-24)



(00-Q) Quiet Creek
Light Etched



(00-C) Colorama
Light Etched



(01-Q) Quiet Creek
Medium Etched



(01-C) Colorama
Medium Etched

(Shown above) Model SPFR-3100-C



ORDERING OPTIONS

Aggregate Color Options:

SPFR-31 -

- 00:** Light Etched
- 01:** Medium Etched
- C:** Colorama
- Q:** Quiet Creek

Part Number

SPFR-31XX-X-

- Optional**
- 31:** Chrome Plated Self-closing Hose Bibb
 - 32:** RCP Hose bibb with VB
 - 32-LK:** RCP Hose bibb with VB and Loose Key
 - 36:** Push Button Jug Filler
 - 37:** Foot spray
 - 40:** Commemorative plaque
 - 85:** Valve Box
 - 96:** Sand strainer plate
 - SMP-24:** Surface mounting plate

*A maximum of 3 options may be added to a fountain.

DIMENSIONS

All dimensions subject to manufacturing variance of plus or minus 1/4" (6 mm)

SPFR-31XX 36" H x 24"W x 24"L / Surface Mount

SPEC

Furnish and install Stern-Williams Aggregate Pedestal Drinking Fountain with Remote Chiller (specify model # and options). Drinking fountain shall be aggregate and provide for 8.0 GPH hermetically sealed removable refrigeration system with reciprocating compressor. Fountain shall have chrome plated brass bubblers. Water pressure range shall be 30-80 PSI. Fountains shall provide for simple flow adjustment without requiring dismantling of fountain with a water flow of 0.5 GPM. Push buttons shall require less than 5 lbs of force in compliance with ADA code. Fountains shall be installed per manufacturers recommendations and instructions. Drinking fountain flow paths are lead-free with reinforced stainless-steel tubing that complies with NSF/ANSI/CAN 61: Q≤1 (AB100) standards. Made in the USA.

SPFR-3100

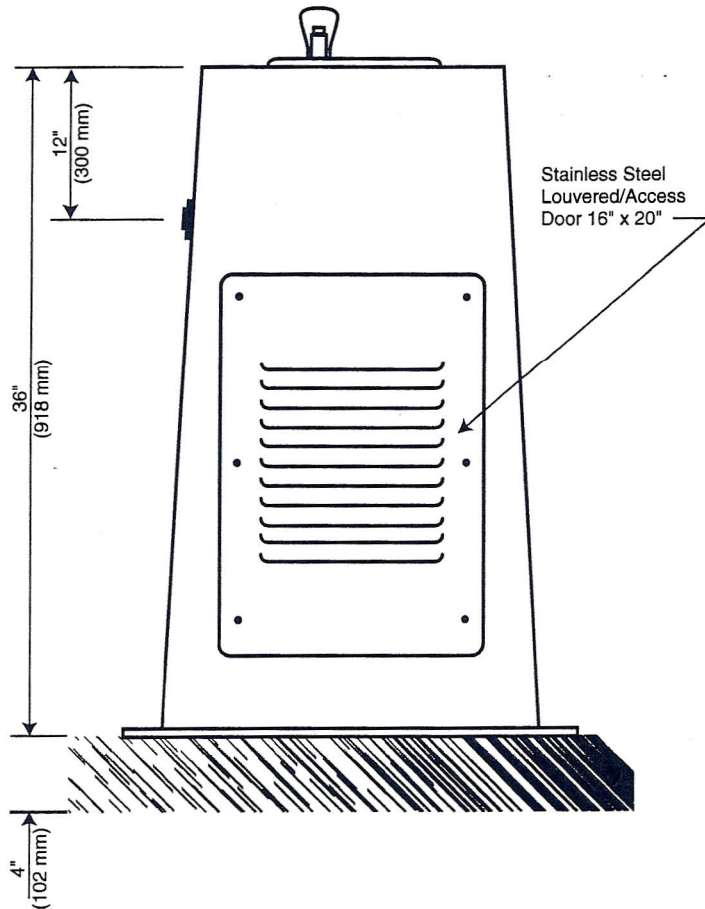
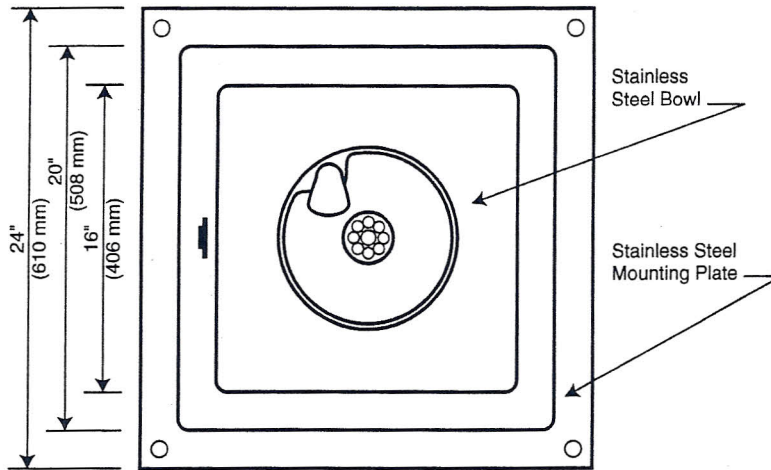

ELECTRIC WATER CHILLER

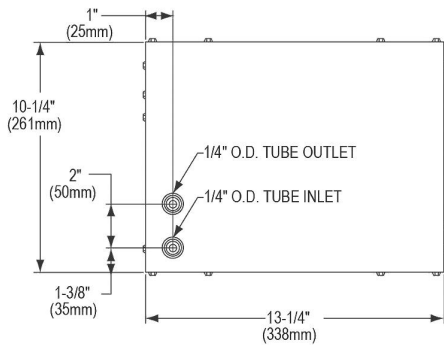

TOP VIEW

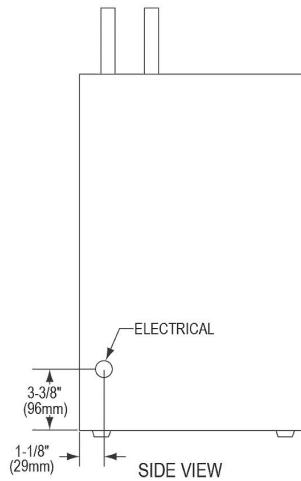

SIDE VIEW

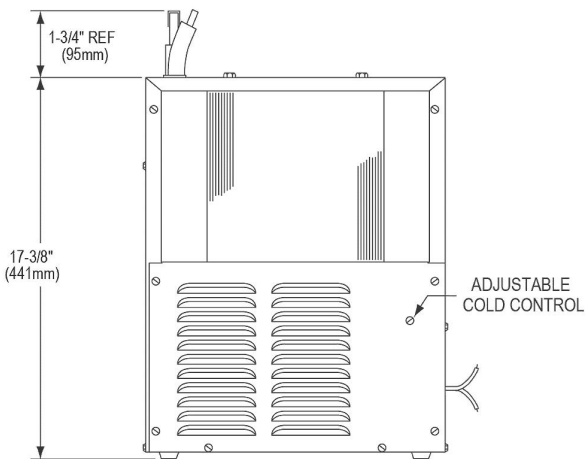

FRONT VIEW

Finish:	Galvanized Steel
Power:	115V/60Hz
Chilling Capacity*:	8.0 GPH
Full Load Amps	5
Rated Watts:	370
Dimensions:	13-1/4" x 10-1/4" x 17-3/8"
Approx. Shipping Weight:	43 lbs.
Installation Location:	Indoor
No. of Stations Served:	2

*Based on 80° F inlet water & 90° F ambient air temp for 50° F chilled drinking water.

Cabinet

Rust-resistant galvanized steel

Compressor

Hermetically-sealed, reciprocating type, single phase. Sealed in lifetime lubrication.

Cooling Unit

Combination tube-tank type. Continuous copper tubing is fully insulated with foam that meets UL requirements for self-extinguishing material.

Refrigeration System

Refrigerant R-134a is controlled accurately calibrated capillary tube.

Condenser/Fan

Fan cooled, copper tube with aluminum fins. Fan motor is permanently lubricated

Thermostat

Easily accessible enclosed adjustable thermostat is factory preset. Requires no adjustment other than for altitude requirements.

Installation

Installs directly under fountain or other application, or may be located in service area to serve up to 2 remote outlets (within 15 feet recommended).

Note:

When mounting unit in an open area, to ensure proper ventilation, maintain a 4" (102mm) clearance from cabinet louvers on each side of chiller. When mounting unit in a cavity or behind a wall, maintain minimum space of 4" (102mm) on each side, 4" (102mm) on top and a depth of 12" (305mm).